

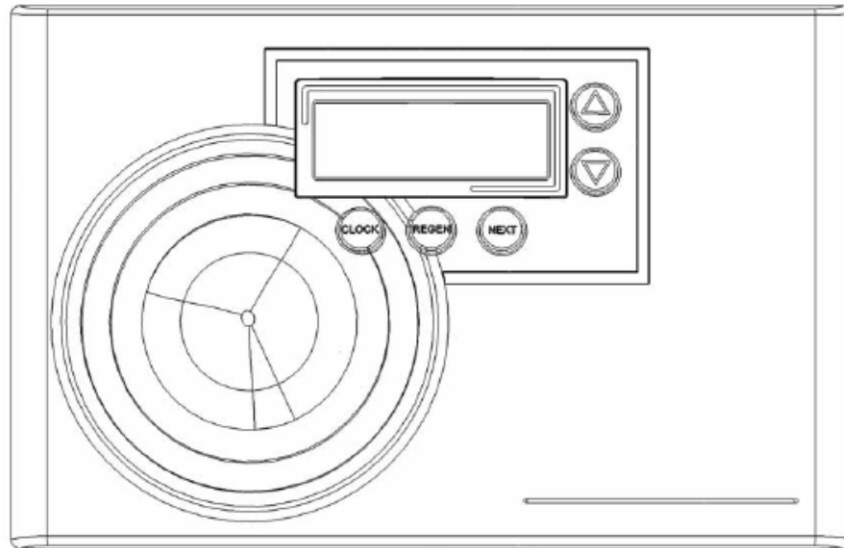

MASTER

Water Conditioning Corp.

Installation and Operation Manual



MP-CLR UF Top Mount Water Softeners

June 2015 Version

Table of Contents

Page No.	Topic	Description
1	Model # and Packaging	Packaging Information
	Component Packaging Description	Packaging Description
	System Media	Media Packaging
2	Softening System	System Positioning
	Water Softener Tank Loading	Filling with Media
	MP-Clear Reflections Control Valve	Attaching Valve to Tank
3	MP-Clear Reflections Control Valve	Attaching Valve, cont'd
4	Service & Drain Piping, General Installation Layout	Drain Piping
5	System Schematic	Piping Layout
6	Electrical Supply	Electrical Requirements
	Brine Tank / Brine Tubing	Brine tank w/shut off
7	Filling Softener with Water	Details for Filling Softener Tank with Water
8	MP-Clear Reflections Control Valve Timer	Setting the timer
9	Final Check	Final Installation Check
10	Manual Regeneration	Instructions for Manual Regeneration
	Power loss/ Error codes	"What if" Instructions
11	Bypass	Bypass Operation
12	Troubleshooting	Problem/ Cause / Solution
13	Troubleshooting	Problem/ Cause / Solution
14	Troubleshooting	Problem/ Cause / Solution
15	Troubleshooting	Problem/ Cause / Solution
16	Troubleshooting	Problem/ Cause / Solution
17	Error Code Troubleshooting	Problem/ Cause / Solution
18	Error Code Troubleshooting, cont'd	Problem/ Cause / Solution, cont'd
19	Valve Parts List	Part Numbers List
20	Valve Parts List	Part Numbers List
21	Valve Parts List	Part Numbers List
22	Valve Parts List	Part Numbers List
23	Valve Parts List	Part Numbers List
24	Warranty	Warranty

Installation and Operating Instructions for
MP-CLEAR REFLECTIONS UPFLOW CONTROL
Top Mount Water Softener

Model #:

_____	MP-CLR-30 UF	1.0 CF Water Softener
_____	MP-CLR-45 UF	1.5 CF Water Softener
_____	MP-CLR-60 UF	2.0 CF Water Softener
_____	MP-CLR-75 UF	2.5 CF Water Softener

Shipping Carton Description / unit:

# of cartons	Contents	Description
1	Mineral tank	Distributor pipe installed
1	Brine tank	464 shutoff valve assembly. *NOTE: MP-Clear Reflections valve is shipped in brine tank.
1	MP-Clear Reflections Upflow control valve	MP-Clear Reflections timer and backwash flow control and bypass with 1" copper or pvc connection
	C-800	1-cubic foot boxes
	C-800	1½- cubic foot boxes

Filter Media is Packaged as Follows:

Model #	Media
MP-CLR-30 UF BY	Preloaded at Factory
MP-CLR-45 UF BY	Preloaded at Factory
MP-CLR-60 UF BY	Preloaded at Factory
MP-CLR-75 UF BY	2-1/2 CF C-800

NOTE: THIS SOFTENER IS NOT INTENDED TO BE USED FOR TREATING WATER THAT IS MICROBIOLOGICALLY UNSAFE OR OF UNKNOWN QUALITY WITHOUT ADEQUATE DISINFECTION WHETHER BEFORE OR AFTER THE SYSTEM.

Water Softener Positioning:

1. Place water softener in desired position, far enough from walls and other obstructions to allow for servicing the unit.
2. Place the water softener within reasonable access to a grounded 115V/60 HZ circuit and a legal drain line connection.

Water Softener Tank Loading:

(Only the MP-CLR-75 needs to be loaded))

1. Remove yellow caplug from top of tank. DO NOT CUT white riser tube. Tube was prefitted at the factory.
2. Check the riser to ensure that it is seated securely in the bottom plate. The top of the distributor pipe will be flush with the top of the tank (this was prefitted at the factory).
3. Cover the top opening of the distributor pipe before filling the tank with media (if necessary).
4. Pour the C-800 provided with the unit into the top of the tank. See page one for your specific model number unit to determine the amount of media to load into the mineral tank.
5. Remove the material used to cover the top opening of the distributor pipe.

MP-Clear Reflections Control Valve:

1. When facing the front of the MP-Clear Reflections timer, the inlet connection is located on the right and the outlet connection is on the left. The control valve's inlet and outlet connections are either 1" copper or PVC equipped with split ring and nut.

Control Valve

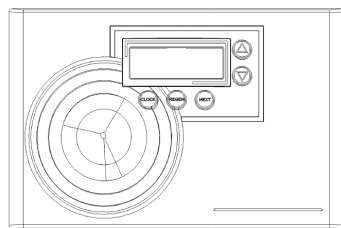

Front View

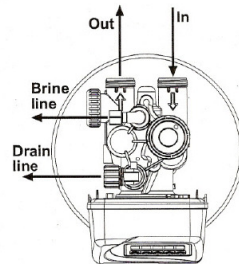

Top View

1. Turn the control valve upside down and ensure that the control valve distributor o'ring is in place. Use silicone lubricant on the o'ring.

****DO NOT USE PETROLEUM!****

****USE ONLY SILICONE ****

2. Place the control valve onto the distributor pipe and into the tank opening.
3. Thread the control valve hand tight . Do not overtighten.
4. Locate the bypass valve assembly that is packaged with the control valve. The bypass valve has two red handles that indicate flow direction, two threaded connections for the tail piece kit and two o'ring seal connections with nuts for the control valve. Align the insert connection ends with o'ring seals and nuts to the inlet and outlet connections of the control valve. Hand tighten the nuts. **DO NOT OVERTIGHTEN THE NUT!**

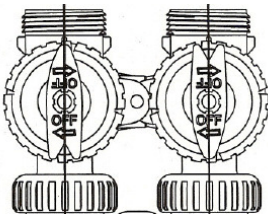

Bypass Valve

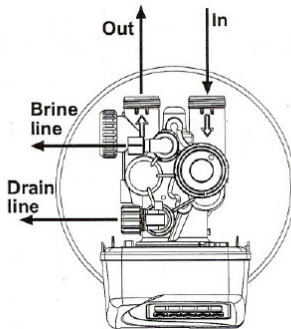

Control Valve

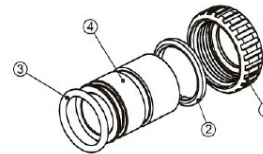

Tail piece assembly

5. Locate the tail piece kit that is packaged with the control valve. The standard tail piece kit is 1" copper with optional 1"/ 3/4" PVC or 3/4" copper kits available as a special order. Each tail piece, o'ring, split ring and nut is presassembled at the factory. Align a tail piece assembly to the bypass valve threaded inlet and insert until the nut can be tightened. Hand tighten the nut because excessive tightening will damage the assembly. **REPEAT THE PROCEDURE FOR THE OUTLET CONNECTION.**

Service and Drain Piping:

1. Pipe water softener into the service lines. The inlet and outlet connections of the control valve are 1" copper or PVC and are located on the back of the valve body. As you face the timer the inlet is on the right and the outlet is on the left. Always follow local plumbing codes when installing our water treatment equipment.
2. If sweat fittings are used, be sure soldering is done in such a manner as not to allow heat to reach the control valve or bypass. (If Schedule 80 PVC is used make sure to follow the proper primer and solvent instructions.)
3. The drain line connection is 5/8" OD or 3/4" npt and is located on the top left of the valve as you face the timer. It is recommended you install a 3/4" union on the drain line for servicing if not using 5/8 OD. The drain line must be of adequate size to allow for full regeneration flow.

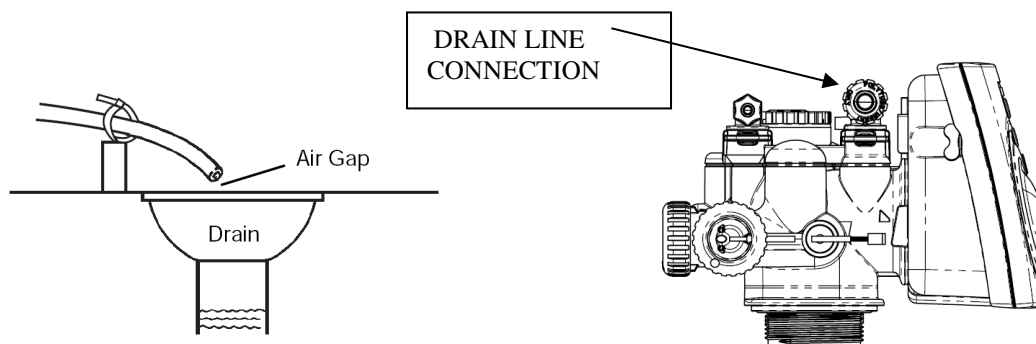

- The control valve drain connection is 3/4" npt.
- Never decrease the drain piping size to below the drain connection size.
- Maximum drain line length is 30 feet with proper sloping the entire length.
- Maximum drain line height is 6 feet above the control valve.
- The drain line must be piped to an open air gap (See Figure above)
- Always follow local plumbing codes.

UNDER NO CIRCUMSTANCES SHOULD THERE BE A DIRECT CONNECTION WITH SANITARY SEWAGE FACILITIES.



MASTER
Water Conditioning Corp.

**TYPICAL PIPING LAYOUT FOR
MP-CLR SERIES SOFTENER**

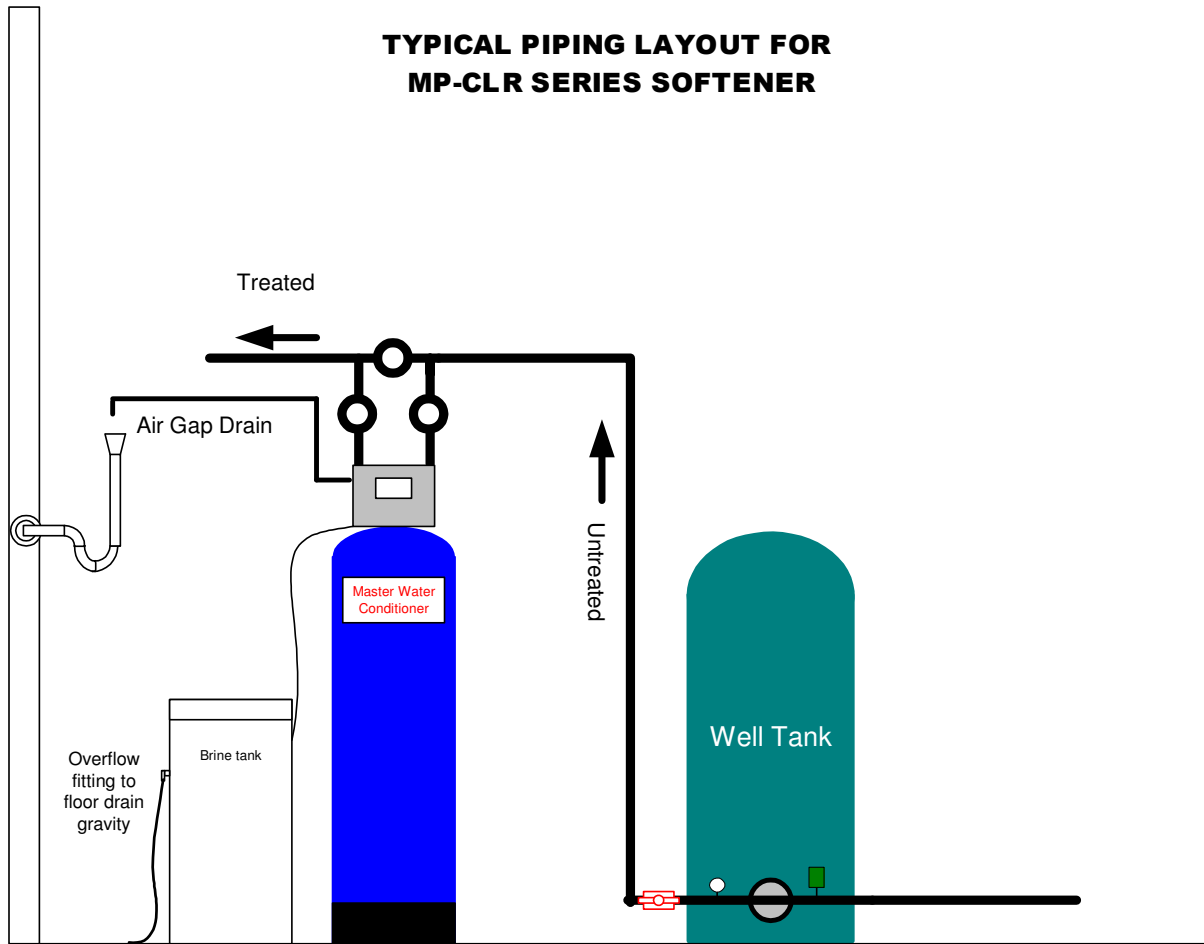

NOTE: All Master Water Conditioners must be installed after the well tank or water meter if its public water supply.

Electrical Requirements:

Always follow all local electrical codes when installing our water treatment equipment.

1. Provide an 115v/60Hz properly grounded dedicated electrical Outlet. (It's very important that the polarity be correct)
Avoid using outlets that are switch controlled.
2. Maximum amperage required is 5 amps.
3. Make sure the electrical service provides power 24 hours per day.
We recommend installing a **surge protector** to protect unit from power surges, which are not covered by warranty.

Brine Tank:

1. The brine tank should be located directly beside the water softener mineral tank.
2. Connect the 3/8" poly tubing to the 3/8" black elbow compression fitting located on the top left side of the MCA control valve.

See Figure Below.

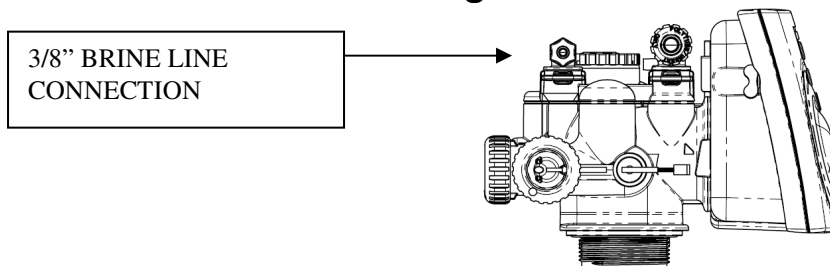

The brine tank is equipped with a shutoff valve, the float height was preset at the factory.

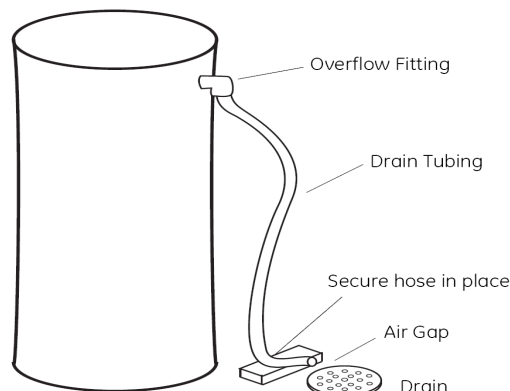

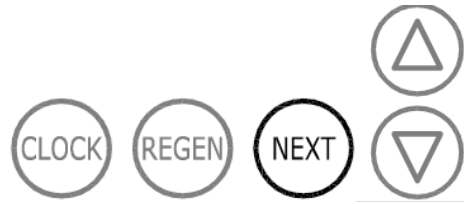

Filling Water Softener with Water:

1. Connect the MP-MCA control valve transformer into the electrical outlet provided.
2. Press and hold the REGEN button until the drive motor starts. When the drive motor stops, the display will read “RINSE” position.
3. Press the REGEN again until the drive motor starts. When the drive motor stops, the display will read “BRINE” position.
4. Press the REGEN again until the drive motor starts. When the drive motor stops, the display will read “RINSE” position. The fast rinse position will rinse the softener tank.
5. Open the inlet ball valve a ¼ turn of its full open position to allow water to enter the water softener mineral tank slowly. The water is going to enter the tank from the bottom of the distributor pipe and leave the tank from the top. This will slowly purge all the air from the tank.

IF WATER ENTERS THE TANK TOO FAST, ALL THE CATION RESIN WILL BE FLUSHED TO DRAIN DURING START UP.

6. When only water is running to the drain, open the inlet and outlet ball valves fully.
7. Press and hold the REGEN button until the drive motor starts. When the drive motor stops, the display will read “FILL” position. The brine tank will fill with the proper amount of water.

NOTE: THE TIMER WILL AUTOMATICALLY ADVANCE TO THE SERVICE POSITION AND THE DISPLAY WILL READ THE CAPACITY REMAINING, IN GALLONS.

MP-Clear Reflections Control Valve Timer Settings:

Note: The control valve is set at the factory. You only need to set the time of day , hardness and regeneration time if required, which is preset at 2 am.

Time of Day Setting

- 1) Press the CLOCK button. The screen will show the Time of Day in blinking numbers.
- 2) To change the Time of Day, use the UP and DOWN arrows to set the Hour.
- 3) To change the Minutes, press CLOCK, use the UP and DOWN arrows to set the Minutes
- 4) Press the CLOCK button.

Hardness Setting (the factory default is 10)

- 1) Press the NEXT and UP arrow , hold for 3 seconds. The screen will show the Hardness as grains per gallon in blinking numbers.
- 2) To change the number, use the UP or DOWN arrows.
- 3) Press the NEXT button.

If water was tested by Master Water Conditioning, follow recommendations on water analysis, for hardness setting.

Regeneration Day Override Setting (the factory default is OFF)

- 1) Press the NEXT button. The screen will show the Regeneration Day Override in blinking numbers.
- 2) To change the number, use the UP or DOWN arrows.
- 3) Press the NEXT button.

Time of Regeneration Setting (the factory default is 2 AM)

- 1) The screen will show the Time of Regeneration in blinking numbers.
- 2) If Regeneration time change is desired, use the UP or DOWN arrows to adjust the hour.
- 3) Press the NEXT button. Use the UP or DOWN arrows to adjust the minutes.
- 4) Press the NEXT button. The display will show the time of day.

NOTE: SALT SETTING AND CAPACITY ARE PRESET AT THE FACTORY.

Final Check:

1. Fill the brine tank with Solar Salt and the Res-Up Feeders with Res-Up (one quart is provided).
2. Make sure the drain line connection meets all plumbing codes and that the drain line size can handle the backwash flow rate of the softener.
3. Make sure the Inlet and Outlet on bypass valve are open.
4. Make sure the control valve timer is plugged into an electrical outlet with power 24 hours per day.
5. Check all piping for leaks.

Manual Regeneration:

Note: For softeners, if brine tank does not contain salt, fill with salt and wait at least 2 hours before regeneration.

To initiate manual regeneration immediately, press and hold the “REGEN” button for three seconds. The system will begin to regenerate immediately. **The request cannot be cancelled.**

To initiate a manual regeneration at the preset delayed regeneration time, when the regeneration time option is set to “NORMAL” or “NORMAL + on 0”, press and release “REGEN”. The words “REGEN TODAY” will flash on the display to indicate that the system will regenerate at the preset delayed regeneration time. If you pressed “REGEN” in error, pressing the button again will cancel the request.

Note: If the regeneration time option is set to “on 0” there is no set delayed regeneration time so “REGEN TODAY” will not activate if “REGEN” button is pressed.

Power Loss

If the power goes out for less than two hours, the system will automatically reset itself. If an extended power outage occurs, the time of day will flash on and off which indicates the time of day should be reset. The system will remember the rest.

Error Message

If the word “ERROR” and a number are alternately flashing on the display, contact a service technician for help. This means the valve is unable to function properly.

BYPASS VALVE OPERATION

Figure 1

NORMAL OPERATION

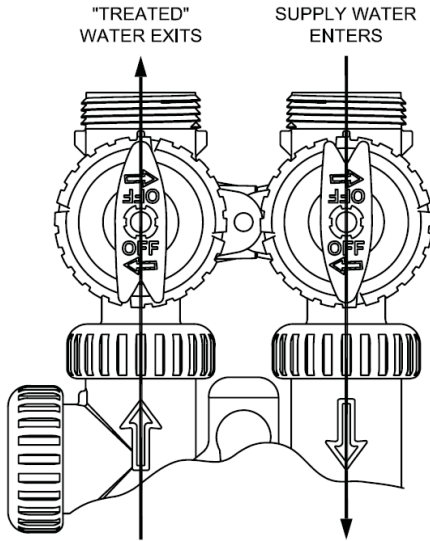

Figure 2

BYPASS OPERATION

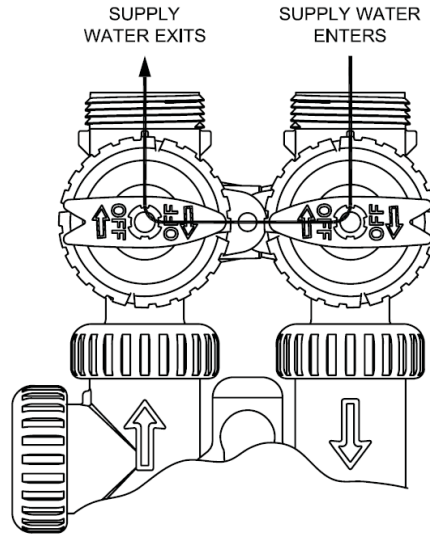

Figure 3

DIAGNOSTIC MODE

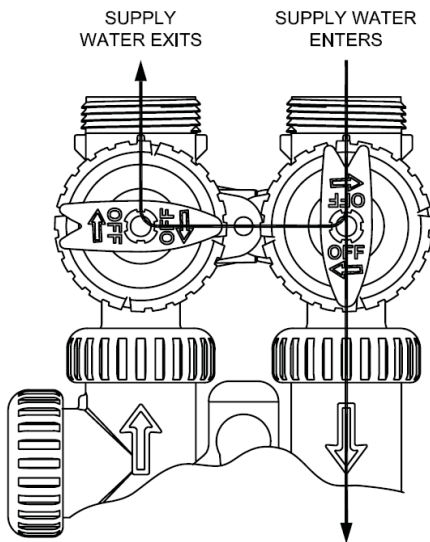
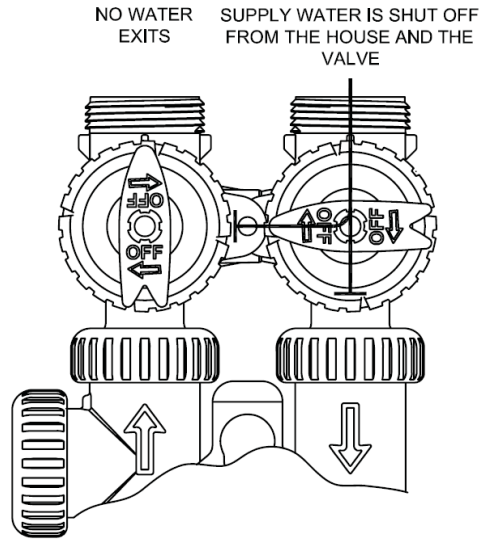

Figure 4

SHUT OFF MODE



Troubleshooting

Problem: Water conditioner fails to regenerate. No soft water.

Possible Cause	Solution
Power supply to MP-Clear Reflections control has been interrupted.	Determine reason for power interruption and correct. Reset time of day.
Water pressure lost.	Restore water pressure.
Corrupted programming of MP-Clear Reflections timer.	Reprogram timer assembly.
Defective MP-Clear Reflections timer.	Replace timer assembly.
No salt in brine tank.	Add salt and regenerate.
Manual bypass valve is open.	Close manual bypass valve.
Leak at riser pipe seal.	Insure that riser pipe is properly sealed at o'ring seal. Inspect pipe for cracks.
Insufficient brine.	Check brine float height and clean assembly if necessary. Check flow rate capabilities of safety float and air check assembly.
Plugged injector or injector screen.	Inspect and clean injector and/or injector screen.

Problem: No Brine Draw

Possible Cause	Solution
Plugged injector or injector screen.	Inspect and clean injector and/or injector screen.
Insufficient water pressure.	Increase water pressure above 25 psig (172kPa) minimum.
Corrupted programming of MP-Clear Reflections timer.	Reprogram timer assembly.
Defective MP-Clear Reflections timer.	Replace timer assembly.
Obstructed drain line.	Remove obstruction.

Problem: Insufficient brine draw

Possible Cause	Solution
Partially clogged injector or injector screen.	Inspect and clean injector and/or injector screen assembly.
Restricted flow rate in brine line.	Check flow rate capabilities of the safety float/aircheck assembly.
Insufficient water pressure.	Increase water pressure above 25 psig (172kPa) minimum.
Excessive back pressure on injector due to elevated drain line.	Reduce drain line elevation to height of valve.
Damaged valve disk.	Replace all valve disks.
Partially restricted drain line.	Remove restriction.

Problem: Insufficient Refill to Brine Tank

Possible Cause	Solution
Brine refill control	Remove and clean
Restricted flow rate in brine line.	Check flow rate capabilities of the safety float/aircheck assembly.

Problem: Excessive Water in Brine Tank

Possible Cause	Solution
Plugged drain line flow control.	Clean flow control.
Plugged injector and/or injector screen	Inspect and clean injector and/or screen.

Problem: Loss of Media to Drain

Possible Cause	Solution
No flow control installed in drain line.	Install drain line flow control.

Problem: Leak to Drain

Possible Cause	Solution
No flow control installed in drain line.	Install drain line flow control.
Insufficient water pressure.	Increase water pressure above 25 psig (172kPa) minimum.
Damaged valve disk or obstruction in valve disk.	Inspect and if damaged, replace all valve disks or remove obstruction.

Problem: Loss of Water Pressure

Possible Cause	Solution
Fouled resin bed due to iron accumulation.	Clean control valve and mineral bed with cleaner.
Slots in riser pipe or laterals are filled with resin fines.	Inspect and clean distributor pipe slots as needed.

Problem: Salt in Water to Service after Regeneration

Possible Cause	Solution
Injector is too small for system size.	Install correct injector
Brine draw time excessively long due to low water pressure.	Increase water pressure above 25 psig (172 kPa) minimum.
Restricted drain line.	Remove drain line restriction.
Insufficient rinse volume.	Increase slow rinse time, fast rinse time, or both.
Damaged valve disk.	Replace all valve disks.
Plugged injector and/or injector screen.	Inspect and clean injector and/or injector screen.

Problem: Timer does not display time of day

Possible Cause	Solution
AC Adapter unplugged	Connect power
No electric power at outlet	Repair outlet or use working outlet
Defective AC Adapter	Replace AC Adapter
Defective PC Board	Replace PC Board

Problem: Timer does not display correct time of day

Possible Cause	Solution
Switched outlet	Use uninterrupted outlet
Power Outage	Reset time of day
Defective PC Board	Replace PC Board

Problem: Control Valve regenerates at wrong time of day

Possible Cause	Solution
Power Outages	Reset control valve to correct time of day
Time of day not set correctly	Reset to correct time of day
Time of regeneration incorrect	Reset regeneration time

Problem: Control valve stalled in regeneration

Possible Cause	Solution
Motor not operating	Replace motor
No electric power at outlet	Repair outlet or use working outlet
Defective AC adapter	Replace AC adapter
Defective PC board	Replace PC board
Broken drive gear or drive cap assembly	Replace drive gear or drive cap assembly
Broken piston retainer	Replace piston retainer
Broken main or regenerate piston	Replace main or regenerate piston

Problem: Control valve does not regenerate automatically when UP and DOWN buttons are held and depressed

Possible Cause	Solution
AC adapter unplugged	Connect AC adapter
No electric power at outlet	Repair outlet or use working outlet
Broken drive gear or drive cap assembly	Replace drive gear assembly
Defective PC board	Replace PC board

Problem: Control valve does not regenerate automatically but does when UP and DOWN buttons are depressed and held

Possible Cause	Solution
Defective PC board	Replace PC board
Set-up error	Check control valve set-up procedure

ERROR CODES

ERROR DESCRIPTIONS

(V3890MP-02 BOARD with 5800.0 Software)

101	UNABLE TO START. Control not sensing valve movement with motor output energized.
102	#1 MAV/Stager #1 MOTOR STALLED. Unable to find proper park position.
103	#1 MAV/Stager #1 MOTOR RAN TOO LONG. Unable to find proper park position.
104	#1 MAV/Stager #1 VALVE HOMING. Control unable to find the HOME position of the valve
106	#2 MAV/Stager #2 MOTOR RAN TOO LONG. Unable to find proper park position.
107	#2 MAV/Stager #2 MOTOR STALLED. Unable to find proper park position.
109	INVALID MOTOR STATE Control can no longer operate due to the detection of an invalid motor state.
116	#3 MAV/Stager #3 MOTOR RAN TOO LONG. Unable to find proper park position.
117	#3 MAV/Stager #3 MOTOR STALLED. Unable to find proper park position.
126	#4 MAV/Stager #4 MOTOR RAN TOO LONG. Unable to find proper park position.
127	#4 MAV/Stager #4 MOTOR STALLED. Unable to find proper park position.
201	INVALID REGEN STEP Control can no longer operate due to the detection of an invalid regeneration cycle step (Internal software error)
402	POWER DOWN MEMORY Control can no longer operate due to a <u>check sum error</u> for the operational data and status section memory
403	PROGRAM MEMORY Control can no longer operate due to a <u>check sum error</u> for the programming section memory
404	DIAGNOSTIC MEMORY Control can no longer operate due to a <u>check sum error</u> for the diagnostic section memory
405	HISTORY MEMORY Control can no longer operate due to a <u>check sum error</u> for the history section memory
406	CONTACT MEMORY Control can no longer operate due to a <u>check sum error</u> for the contact screen section memory.

- 407 STATUS RAM MEMORY FAILURE Control can no longer operate due to corrupted data detected in the operational and status section. Once generated the error mode is not entered nor an error display viewed.
Instead previous (<6 hours) data is used
- 408 DIAGNOSTIC RAM MEMORY FAILURE Control can no longer operate due to corrupted data detected in the diagnostic section. Once generated, the error mode is not entered nor an error display viewed.
Instead previous (<6 hours) data is used.
- 410 CONFIG DOWNLOAD Configurator file downloaded to the control was not originally uploaded from another control with the identical software.

CLEAR REFLECTIONS PARTS

Refill Flow Control Assembly and Refill Port Plug

Drawing No.	Order No.	Description	Quantity
1	V3195-01	WS1 Refill Port Plug ASY	This part is required for backwash only systems
2	H4615	Elbow Locking Clip	1
3	JCP-P-6	Polytube insert 3/8"	1
4	JCPG-6PBLK	Nut 3/8"	1
5	H4613	Elbow Cap 3/8"	1
6	V3163	O-ring 019	1
7	V3165-01*	WS1 RFC Retainer ASY	1
8	V3182	WS1 RFC	1
Not Shown	H4650	Elbow 1/2" with nut and insert	Option

*Assembly includes WS1 RFC.

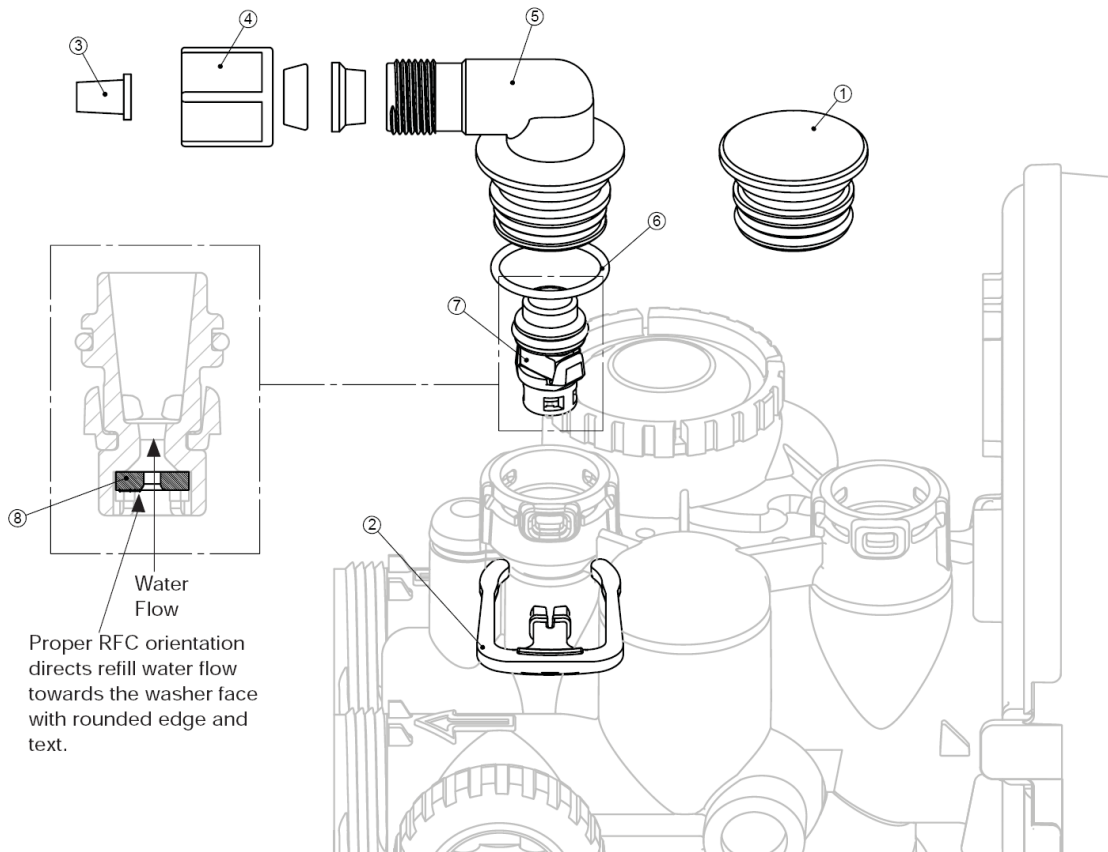

CLEAR REFLECTIONS PARTS

Injector Cap, Injector Screen, Injector, Plug and O-Ring

Drawing No.	Order No.	Description	Quantity
1	V3176	Injector Cap	1
2	V3152	O-ring 135	1
3	V3177	Injector Screen	1
4	V3010-1Z	WS1 Injector ASY Z Plug	1
5	V3010-1A	WS1 INJECTOR ASY A BLACK	1
	V3010-1B	WS1 INJECTOR ASY B BROWN	
	V3010-1C	WS1 INJECTOR ASY C VIOLET	
	V3010-1D	WS1 INJECTOR ASY D RED	
	V3010-1E	WS1 INJECTOR ASY E WHITE	
	V3010-1F	WS1 INJECTOR ASY F BLUE	
	V3010-1G	WS1 INJECTOR ASY G YELLOW	
	V3010-1H	WS1 INJECTOR ASY H GREEN	
	V3010-1I	WS1 INJECTOR ASY I ORANGE	
	V3010-1J	WS1 INJECTOR ASY J LIGHT BLUE	
	V3010-1K	WS1 INJECTOR ASY K LIGHT GREEN	
Not Shown	V3170	O-ring 011	*
Not Shown	V3171	O-ring 013	*

*The injector plug and the injector each contain one 011 (lower) and 013 (upper) o-ring.

Note: For upflow position, injector is located in the up hole and injector plug is in the other hole. WS1MR upflow bodies are identified by having the DN marking removed. For a filter that only backwashes, injector plugs are located on both holes.

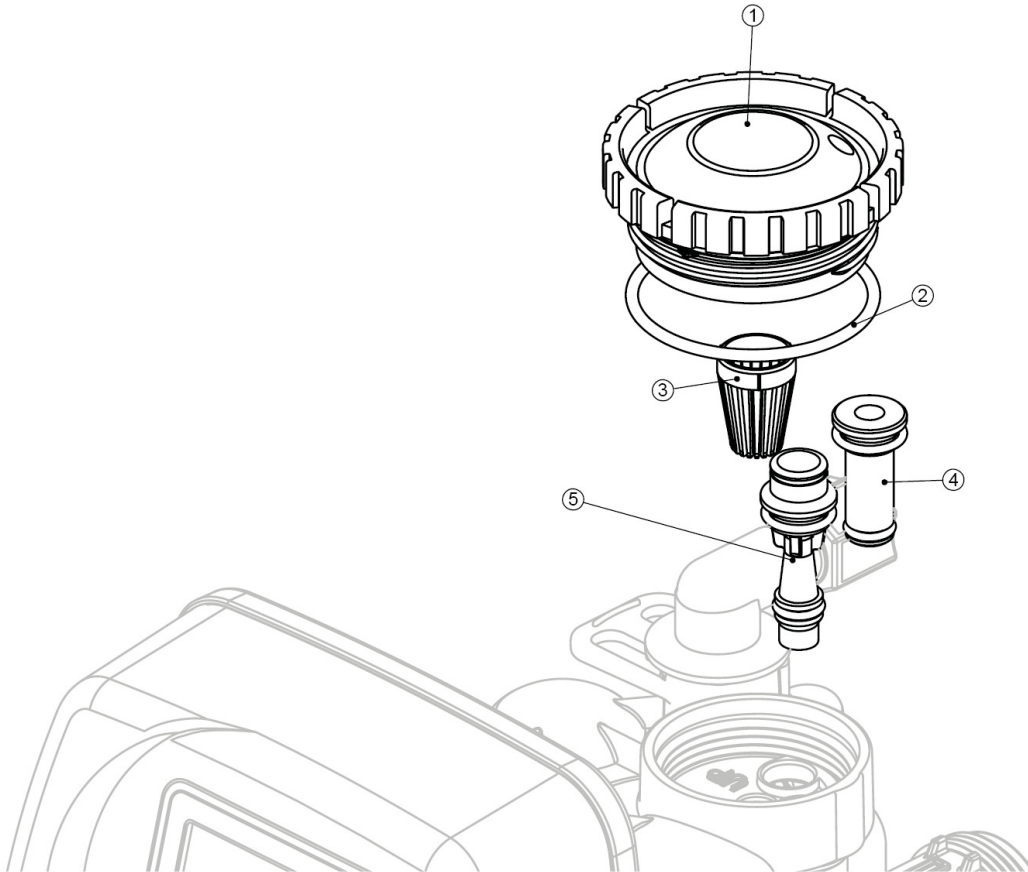

CLEAR REFLECTIONS PARTS

MP Front Cover and Drive Assembly

Drawing No.	Order No.	Description	Quantity
1	V3371-01	WS1MR FRONT COVER ASSEMBLY	1
2	V3107-01	WS1 MOTOR	1
3	V3106-01	WS1 DRIVE BRACKET & SPRING CLIP	1
4	V3890MP-02BOARD	WS1THRU2L/2 MP PCB XMEGA REPLACE	1
5	V3110	WS1 DRIVE REDUCING GEAR 12X36	3
6	V3109	WS1 DRIVE GEAR COVER	1
NOT SHOWN	V3186	WS1 AC ADAPTER 120V-12V	1
	V3186-01	WS1 AC ADAPTER CORD ONLY	
NOT SHOWN	V3372	WS1MR DRIVE BACK PLATE	1
NOT SHOWN	V3463	WS1MR QUARTER TURN FASTENERS	2
NOT SHOWN	V3466	O-RING 008	2

Refer to Control Valve Service Manual for other drawings and part numbers.

AC Adapter	U.S.
Supply Voltage	120 V AC
Supply Frequency	60 Hz
Output Voltage	12 V AC
Output Current	500 mA

Relay Specifications: 12V DC Relay with a coil resistance not less than 80 ohms. If mounting the relay under the cover check for proper mounting location dimensions on the backplate.

Wiring For Correct On/Off Operation	
PC Board Relay Terminal Block	Relay
RLY 1	Coil -
V +	Coil +
RLY 2	Coil -

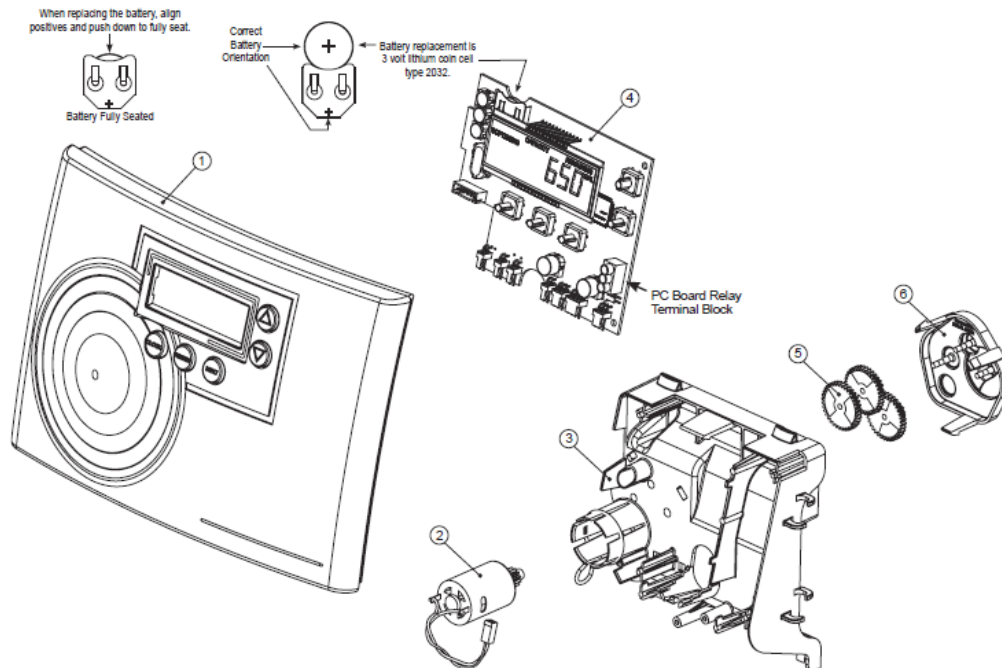

CLEAR REFLECTIONS PARTS

Drawing No.	Order No.	Description	Quantity
1	V3005	WS1 Spacer Stack Assembly	1
2	V3004	Drive Cap ASY	1
3	V3372	WS1MR Drive Back Plate	1
4	V3011	WS1 Piston Downflow ASY	1
5	V3174	WS1 Regenerant Piston	1
6	V3135	O-ring 228	1
7	V3180	O-ring 337	1
8	V3105	O-ring 215 (Distributor Tube)	1
9	V3466	O-ring 008	2
10	V3463	WS1MR Quarter Turn Fasteners	2
Not Shown	V3001	WS1 Body ASY Downflow	1
	V3001-02	WS1 Mixing Valve Body ASY	
	V3001UP	WS1 Body ASY Upflow	
	V3001-02UP	WS1 Mixing Valve Body Upflow ASY	
Not Shown	V3013	WS1 Mixing Valve ASY	1

Note: The regenerant piston is not used in backwash only applications.

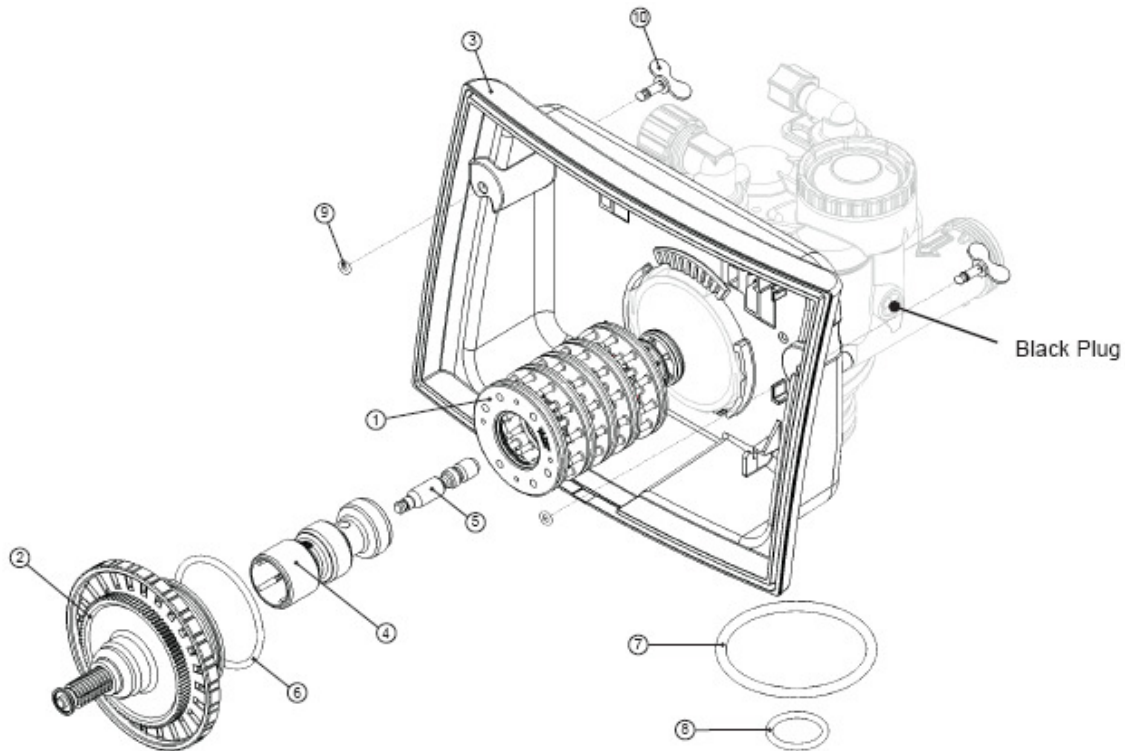

Water Meter, Meter Plug and Mixing Valve

Drawing No.	Order No.	Description	Quantity
1	V3151	WS1 Nut 1" QC	1
2	V3003*	WS1 Meter ASY	1
3	V3118-01	WS1 Turbine ASY	1
4	V3105	O-ring 215	1
5	V3003-01	WS1 Meter Plug ASY	1
6	V3013	Mixing Valve	Optional

* Order number V3003 includes V3118-01 WS1 Turbine Asy and V3105 O-ring 215.

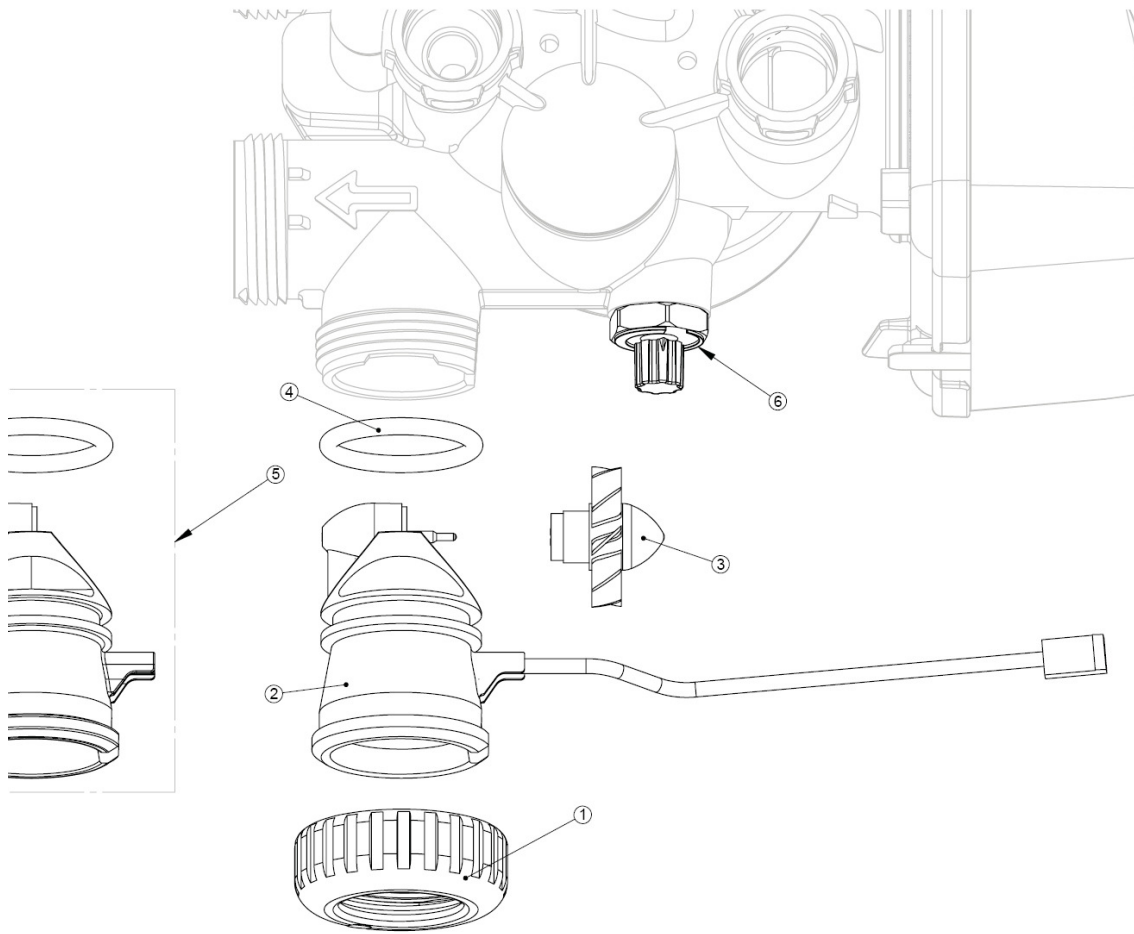

12 YEAR LIMITED WARRANTY

As of Oct. 1, 1995

This Residential Water Conditioner is warranted for a period of **one year** from date of purchase by first user against defects in materials and workmanship. In addition, the complete control valve is warranted for **five years**. The control valve body (excluding internals and electrical parts) is warranted for **six years**. The mineral tank, plastic brine tank or cabinet tank (excluding mineral) is warranted against rust, corrosion or bursting for a period of **twelve years** from date of manufacture. Except, as specifically set forth in this paragraph, Master Water Conditioning Corporation makes no other warranties, express or implied.

This warranty shall be void if the conditioner is moved from the place of original installation, or if damage is caused by misuse, misapplication, accident, freezing, flood, fire or if not installed in accordance with instructions furnished by Master Water Conditioning Corporation.

This warranty shall be void in the event of damages from external sources or where the conditioner has been operated at pressure in excess of 100 pounds per square inch or at a temperature greater than 100 degrees F. or less than 32 degrees F. Incidental costs or consequential damages are not covered by this warranty.

All defective parts shall be returned prepaid to Master Water Conditioning Corporation for inspection. **Master shall not be liable for labor charges other than Master factory repairs.**

This warranty gives you specific legal rights, and you may have other rights which vary from state to state. Some states do not allow limitations on duration of implied warranties or exclusion of incidental or consequential damages, so the above limitations may not apply to you.

All claims must be submitted in writing to Master Water Conditioning Corporation at 224 Shoemaker Road, Pottstown, Pennsylvania 19464 within thirty (30) days from the discovery of the defect. Master Water Conditioning Corporation thereafter will correct defective parts and workmanship or rusting, corrosion or bursting within sixty (60) days.

Failure to notify Master by completing, signing and returning the registration card within twenty (20) days of the purchase shall void the warranty.



MASTER
Water Conditioning Corp.

224 Shoemaker Rd. Pottstown, Pa. 19464

MP-CLR-XXX UF METER SOFTENER

NORMAL VIEW

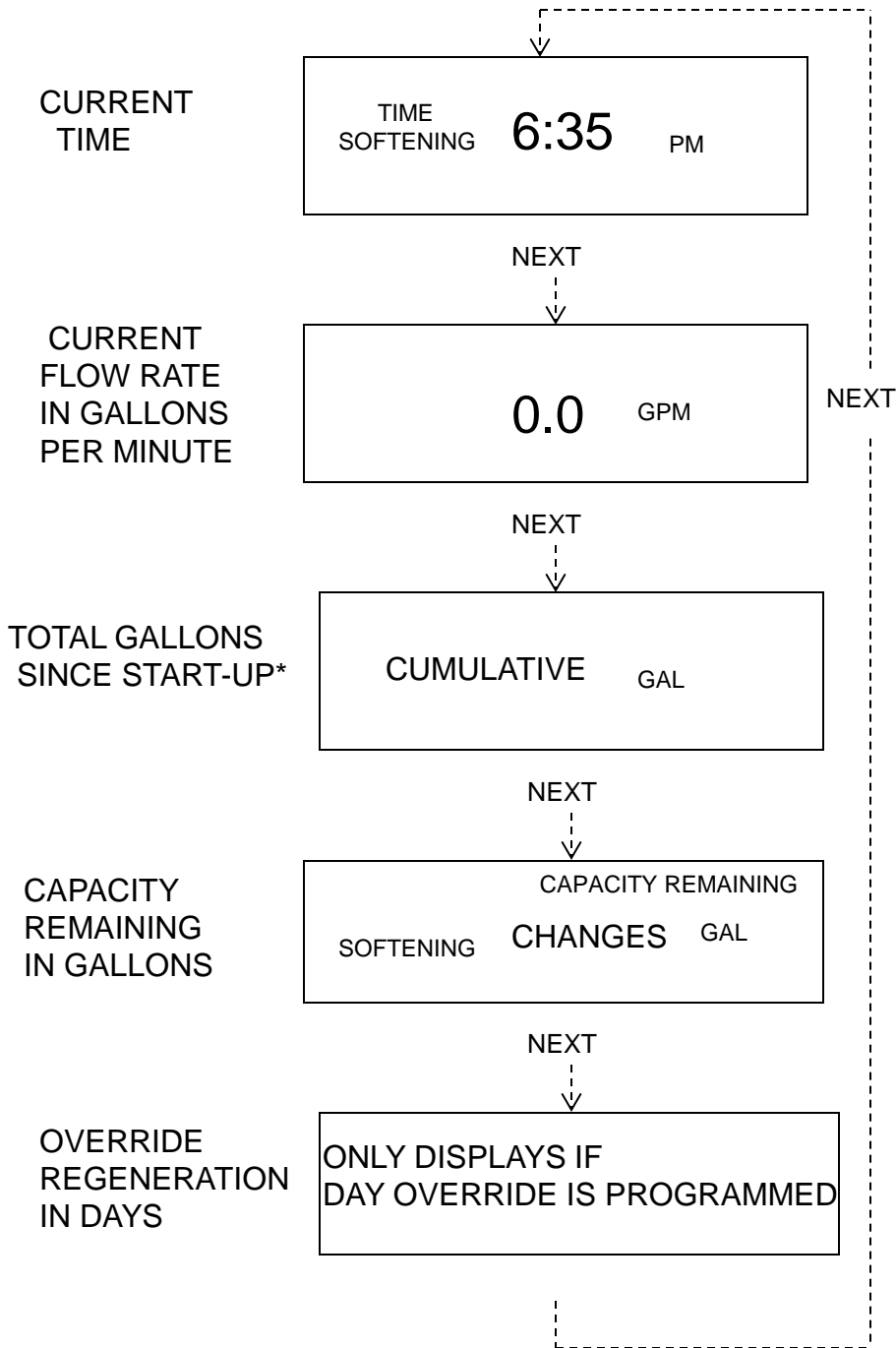

*RESET TO "0" BY PRESSING "CLOCK" AND "REGEN" FOR 3 SECONDS

INSTALLER SETTINGS

NEXT AND ▲



10

HARDNESS

NEXT



Off

DAY OVERRIDE
(Default is OFF)

NEXT



2:

REGEN TIME: HOUR

NEXT



:00

REGEN TIME: MINUTES

SET TIME CLOCK

CLOCK



12:00

TO CHANGE TIME USE



REFERENCE ONLY VALVE PROGRAMING

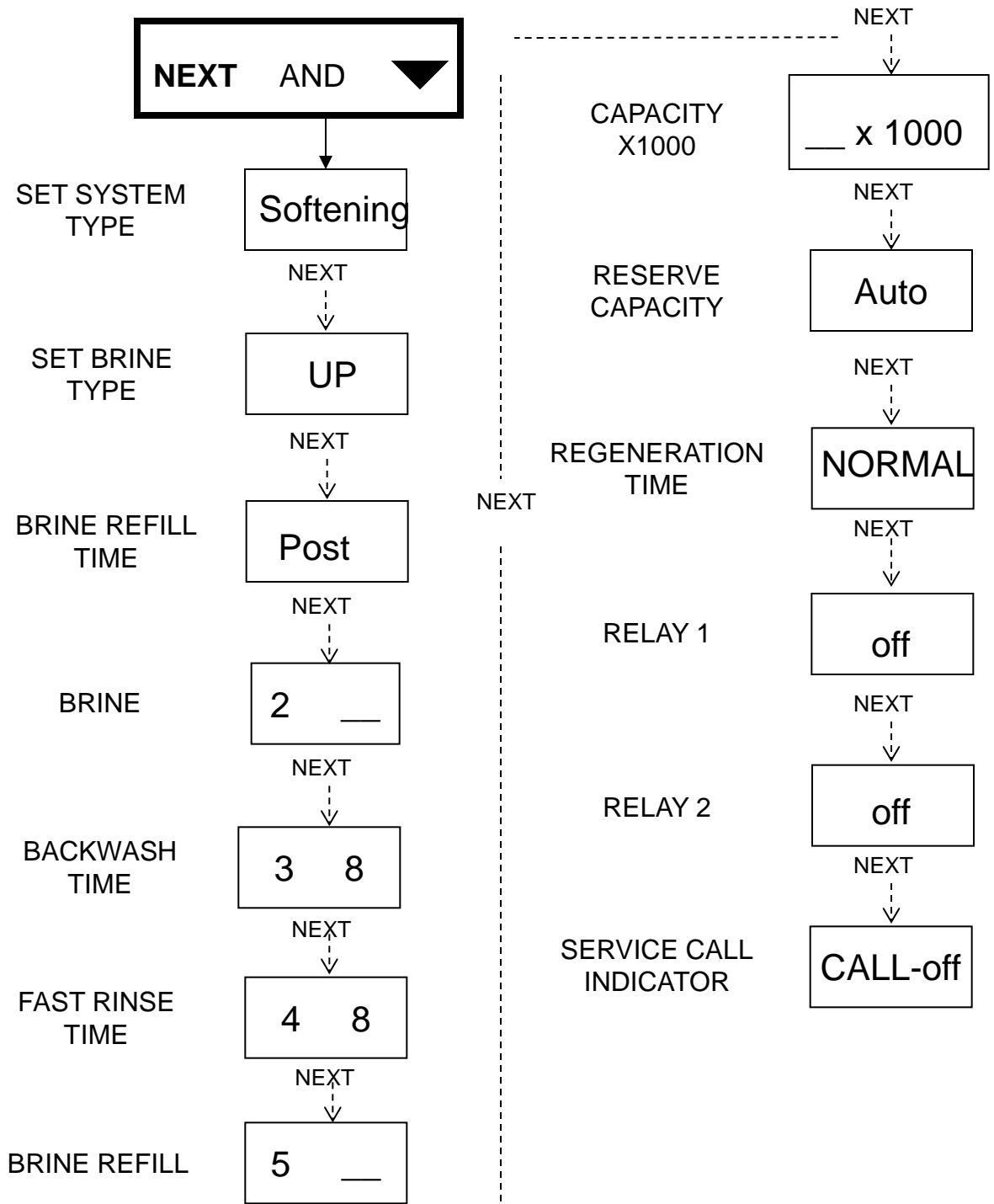

REFERENCE ONLY VALVE PROGRAMING

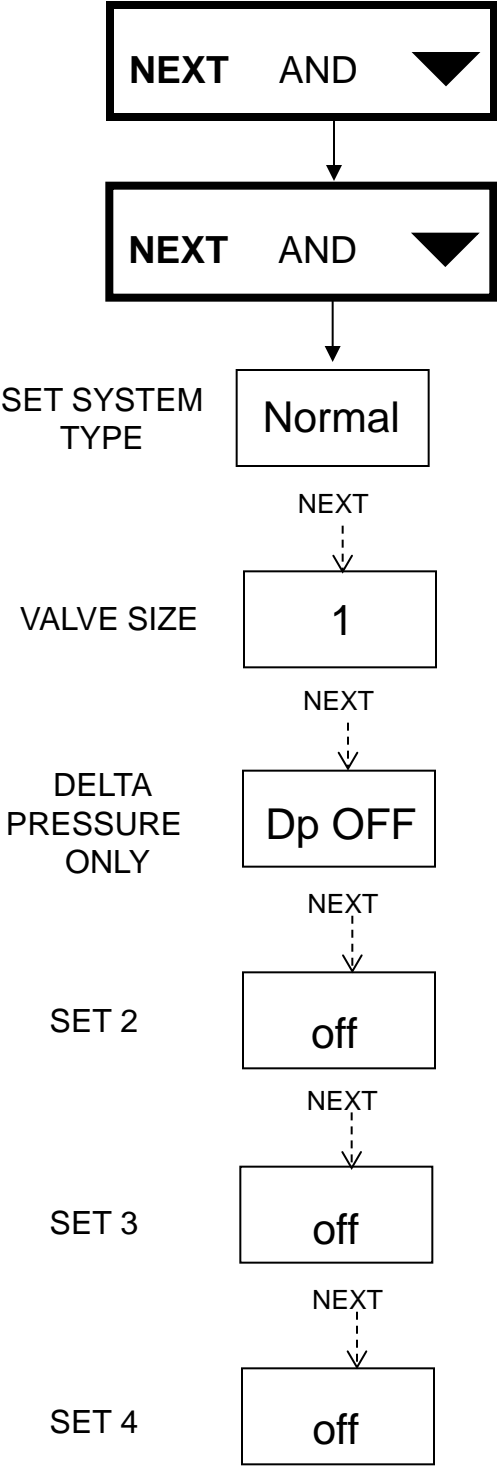

MCA BOARD

DIAGNOSTICS

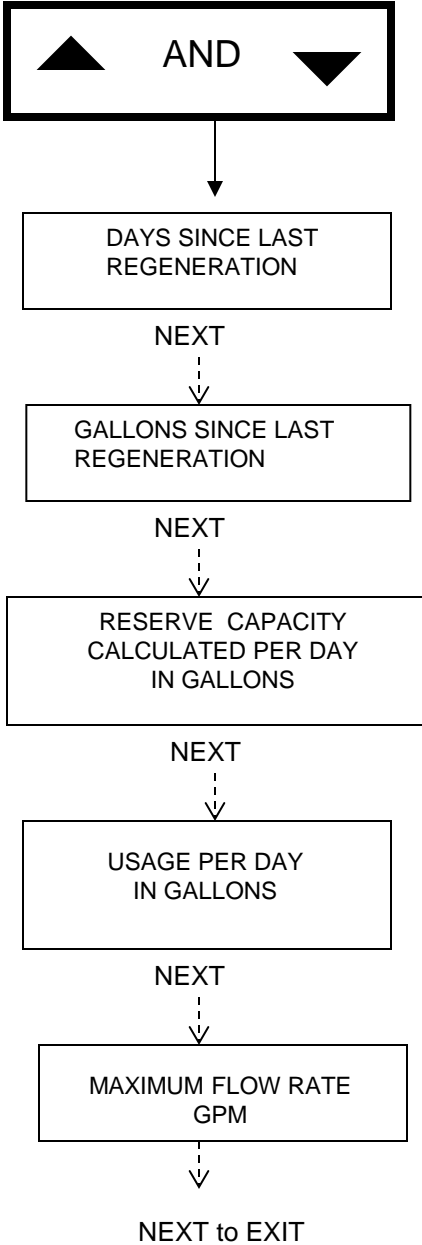

VALVE HISTORY

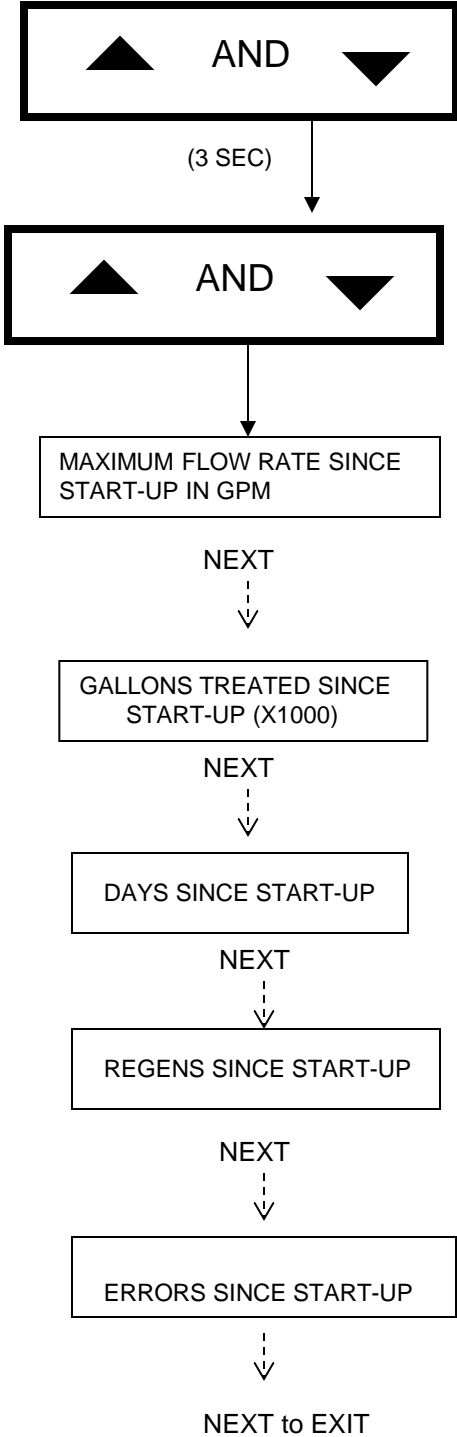

MANUAL REGENERATION

REGEN

PRESS ONCE FOR NEXT REGEN TIME
PRESS AGAIN TO CANCEL REGENERATION
PRESS AND HOLD FOR 3 SECONDS FOR IMMED
PRESS IN REGEN TO ADVANCE TO NEXT CYCLE

LOCKING SETTINGS

AFTER SETTING A VALUE...

LOCK/UNLOCK:



NEXT REGEN



(IN SEQUENCE)

ERROR CODES

ERROR DESCRIPTIONS

(V3890MP-02 BOARD with 5800.0 Software)

101	UNABLE TO START. Control not sensing valve movement with motor output energized.
102	#1 MAV/Stager #1 MOTOR STALLED. Unable to find proper park position.
103	#1 MAV/Stager #1 MOTOR RAN TOO LONG. Unable to find proper park position.
104	#1 MAV/Stager #1 VALVE HOMING. Control unable to find the HOME position of the valve
106	#2 MAV/Stager #2 MOTOR RAN TOO LONG. Unable to find proper park position.
107	#2 MAV/Stager #2 MOTOR STALLED. Unable to find proper park position.
109	INVALID MOTOR STATE Control can no longer operate due to the detection of an invalid motor state.
116	#3 MAV/Stager #3 MOTOR RAN TOO LONG. Unable to find proper park position.
117	#3 MAV/Stager #3 MOTOR STALLED. Unable to find proper park position.
126	#4 MAV/Stager #4 MOTOR RAN TOO LONG. Unable to find proper park position.
127	#4 MAV/Stager #4 MOTOR STALLED. Unable to find proper park position.
201	INVALID REGEN STEP Control can no longer operate due to the detection of an invalid regeneration cycle step (Internal software error)
402	POWER DOWN MEMORY Control can no longer operate due to a <u>check sum error</u> for the operational data and status section memory
403	PROGRAM MEMORY Control can no longer operate due to a <u>check sum error</u> for the programming section memory
404	DIAGNOSTIC MEMORY Control can no longer operate due to a <u>check sum error</u> for the diagnostic section memory
405	HISTORY MEMORY Control can no longer operate due to a <u>check sum error</u> for the history section memory
406	CONTACT MEMORY Control can no longer operate due to a <u>check sum error</u> for the contact screen section memory.

- 407 STATUS RAM MEMORY FAILURE Control can no longer operate due to corrupted data detected in the operational and status section. Once generated the error mode is not entered nor an error display viewed.
Instead previous (<6 hours) data is used
- 408 DIAGNOSTIC RAM MEMORY FAILURE Control can no longer operate due to corrupted data detected in the diagnostic section. Once generated, the error mode is not entered nor an error display viewed.
Instead previous (<6 hours) data is used.
- 410 CONFIG DOWNLOAD Configurator file downloaded to the control was not originally uploaded from another control with the identical software.